

The background of the entire page is a grayscale, semi-transparent image of interlocking gears. In the center, two pneumatic cylinders are shown horizontally, one slightly above the other. The top cylinder is larger and has a more complex end fitting, while the bottom one is smaller and simpler. The overall aesthetic is industrial and technical.

Dynamax® Pneumatics

ISO 6432 Interchangeable Cylinders

144 Kay Drive Easley, SC 29640

Dynamax® ISO 6432 Cylinders



End Caps	<i>Anodized Aluminum</i>
Tube	<i>Stainless Steel AISI 304</i>
Piston	<i>Brass</i>
Seals	<i>ø 8 - 10 - 12 Polyurethane + NBR ø 16 - 20 - 25 Polyurethane</i>
Rod Bushing	<i>Sintered Bronze</i>
Piston Rod	<i>Stainless Steel AISI 303</i>

Working Pressure	<i>1 to 10 bar</i>	
Temperature	<i>ø 8 - 12</i>	<i>20°C + 80°C with dry air</i>
	<i>ø 8 - 12</i>	<i>35°C + 80°C with dry air</i>
Working Fluid	<i>Filtered compressed air, lubricated or not</i>	

Available Versions

SE	Single Acting
SEM	Single Acting, Magnetic
DE	Double Acting
DEM	Double Acting, Magnetic
DEP	Double Acting, Through Piston Rod
DEMP	Double Acting, Magnetic, Through Piston Rod
DEA	Double Acting, Cushioned
DEMA	Double Acting, Magnetic, Cushioned
DEAP	Double Acting, Cushioned, Through Piston Rod
DEMAP	Double Acting, Magnetic, Cushioned, Through Piston Rod

Standard Strokes

Double Acting

Ø mm	10	25	40	50	80	100	125	160	200	250	300	320	400	500
8	•	•	•	•	•	•								
10	•	•	•	•	•	•								
12	•	•	•	•	•	•	•	•	•					
16	•	•	•	•	•	•	•	•	•					
20	•	•	•	•	•	•	•	•	•	•	•	•	•	
25	•	•	•	•	•	•	•	•	•	•	•	•	•	•

Single Acting

Ø mm	10	25	50
8	•	•	•
10	•	•	•
12	•	•	•
16	•	•	•
20	•	•	•
25	•	•	•

144 Kay Drive Easley, SC 29640

Dynamax® ISO 6432 Cylinders

Single Acting Minicylinders

SE / SEM

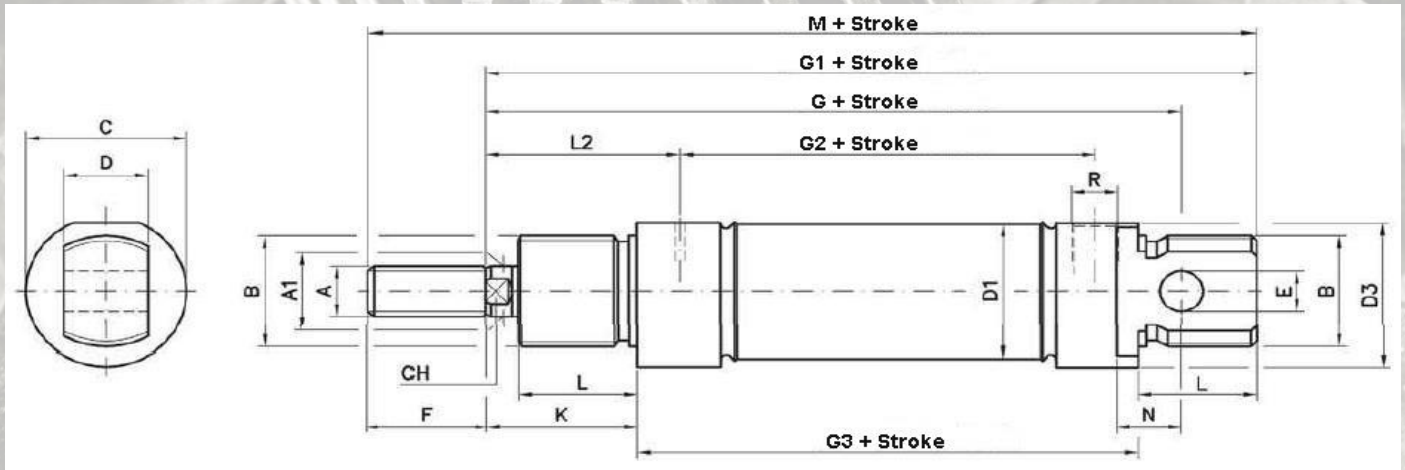

Dimensions

Ø mm	A	A1	B	C	D	D1	D3	E	F	G	G1	G2	G3	K	L	L2	N	CH	R	M
8	M4	4	M12x1.25	16	8	9.27	15	4	12	64	74	36	46	16	12	21	6	/	M5	86
10	M4	4	M12x1.25	16	8	11.27	15	4	12	64	74	36	46	16	12	21	6	/	M5	86
12	M6	6	M16x1.5	19	12	13.27	18	6	16	75	88	38	48	22	18	27	9	5	M5	104
16	M6	6	M16x1.5	19	12	17.27	18	6	16	82	93	43	53	22	18	27	9	5	M5	109
20	M8	8	M22x1.5	27	16	21.27	25.5	8	20	95	111	51.5	67	24	20	32	12	7	G1/8	131
25	M10x125	10	M22x1.5	30	16	26.5	25.5	8	22	104	118	52	68	28	22	36	12	9	G1/8	140

Traction & Thrust Forces (6 Bar)

Ø mm	TRACTION FORCE (N)	THRUST FORCE (N)					
		STROKE 10		STROKE 25		STROKE 50	
		F1	F2	F1	F2	F1	F2
8	19.8	4.7	5.2	4.1	5.2	3	5.2
10	34.2	4.3	5.4	2.8	5.4	-	-
12	38.7	11.1	12.1	9.7	12.1	7.3	12.1
16	86	16.2	17.6	14	17.6	10.2	17.6
20	107.3	47.3	51	41.8	51	32.5	51
25	221.3	24.2	26	21.5	26	16.9	26

Dynamax® ISO 6432 Cylinders

Double Acting Minicylinders

DE / DEM

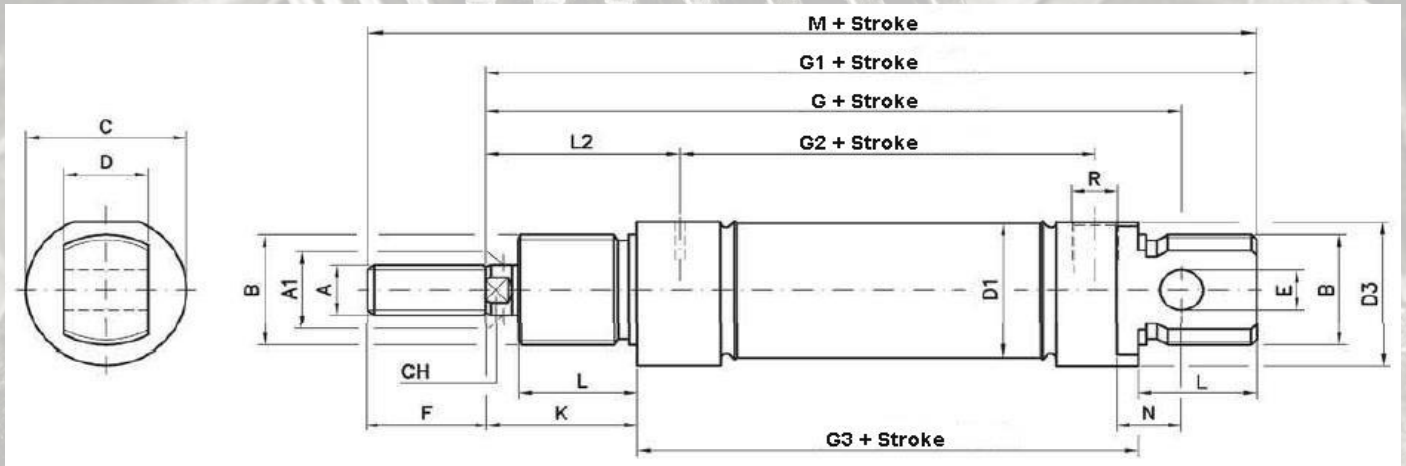

Dimensions

\varnothing mm	A	A1	B	C	D	D1	D3	E	F	G	G1	G2	G3	K	L	L2	N	CH	R	M
8	M4	4	M12x1.25	16	8	9.27	15	4	12	64	74	36	46	16	12	21	6	/	M5	86
10	M4	4	M12x1.25	16	8	11.27	15	4	12	64	74	36	46	16	12	21	6	/	M5	86
12	M6	6	M16x1.5	19	12	13.27	18	6	16	75	88	38	48	22	18	27	9	5	M5	104
16	M6	6	M16x1.5	19	12	17.27	18	6	16	82	93	44	53	22	18	27	9	5	M5	109
20	M8	8	M22x1.5	27	16	21.27	25.5	8	20	95	111	51.5	67	24	20	32	12	7	G1/8	131
25	M10x125	10	M22x1.5	30	16	26.5	28.5	8	22	104	118	52	68	28	22	36	12	9	G1/8	140

Traction & Thrust Forces (6 Bar)

\varnothing mm	THRUST FORCE (N)	TRACTION FORCE (N)
8	24	15
10	41	32
12	55	38
16	105	88
20	165	141
25	266	219

144 Kay Drive Easley, SC 29640

Dynamax® ISO 6432 Cylinders

Through Piston Rod Double Acting Minicylinders

DEP / DEMP

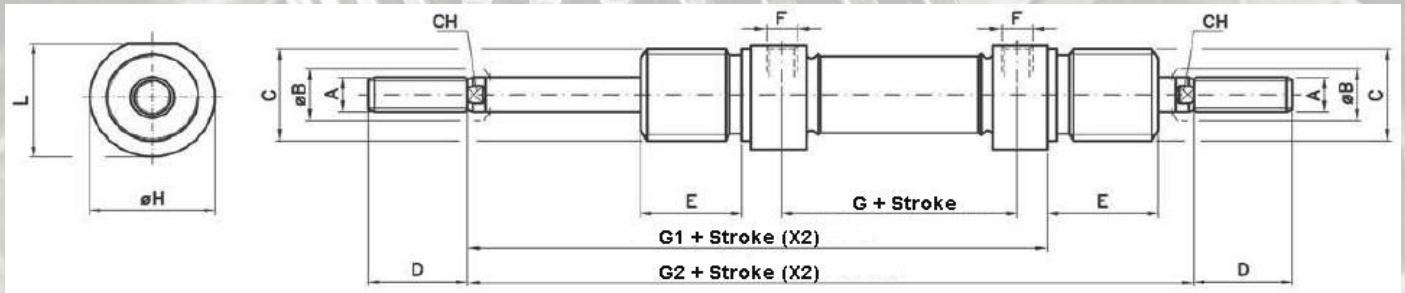

Dimensions

\varnothing mm	A	$\varnothing B$	C	D	E	F	G	G1	G2	$\varnothing H$	L	CH
8	M4	4	M12x1.25	12	12	M5	36	62	78	16	15	/
10	M4	4	M12x1.25	12	12	M5	36	62	78	16	15	/
12	M6	6	M16x1.50	16	18	M5	38	70	92	19	18	5
16	M6	6	M16x1.50	16	18	M5	44	75	97	19	18	5
20	M8	8	M22x1.5	20	20	G1/8	51.5	91	115	27	26	7
25	M10x1.25	10	M22x1.5	22	22	G1/8	52	96	124	30	29	9

Traction & Thrust Forces (6 Bar)

\varnothing mm	THRUST FORCE (N)	TRACTION FORCE (N)
8	24	15
10	41	32
12	55	38
16	105	88
20	165	141
25	266	219

Dynamax® ISO 6432 Cylinders

Double Acting Cushioned Minicylinders

DEA / DEMA

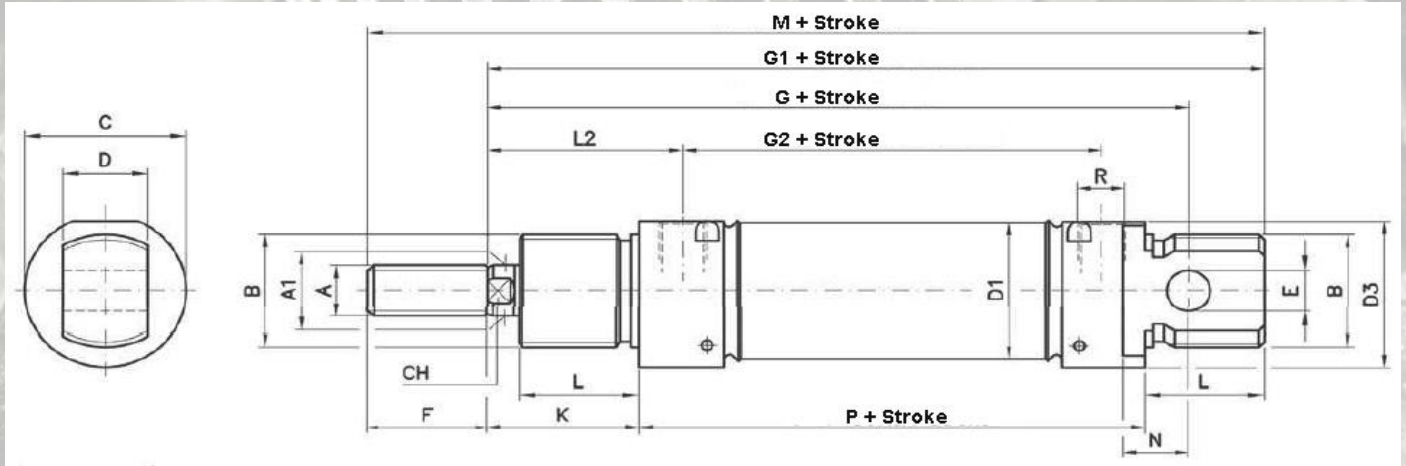

Dimensions

Ø mm	A	A1	B	C	D	D1	D3	E	F	G	G1	G2	K	L	L2	N	CH	R	P	M
16	M6	6	M16x1.5	21	12	17.27	20	6	16	82	93	44	21	17	27	9	5	M5	55	109
20	M8	8	M22x1.5	27	16	21.27	25.5	8	20	95	111	51	24	20	32	12	7	G1/8	67	131
25	M10x1.25	10	M22x1.5	30	16	26.5	28.5	8	22	104	118	52	28	22	36	12	9	G1/8	68	140

Traction & Thrust Forces (6 Bar)

Ø mm	THRUST FORCE (N)	TRACTION FORCE (N)
16	105	88
20	165	141
25	266	219

Dynamax® ISO 6432 Cylinders

Through Rod Double Acting Cushioned Minicylinders

DEAP / DEMAP

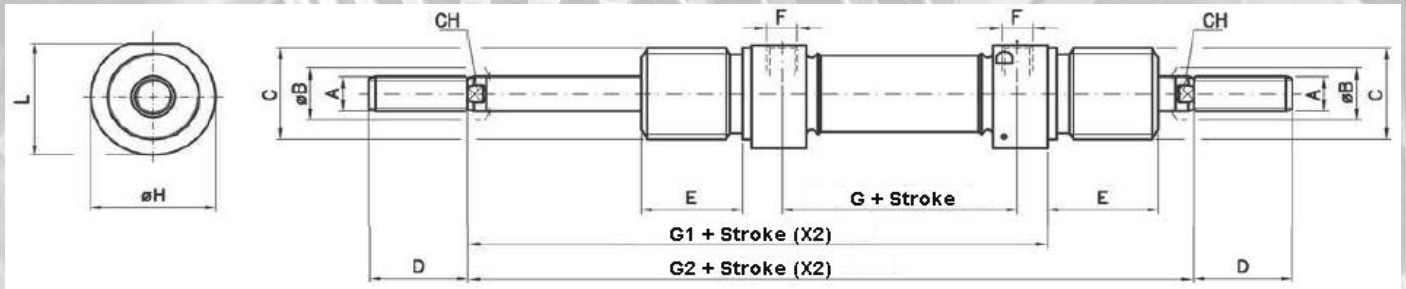

Dimensions

\varnothing mm	A	$\varnothing B$	C	D	E	F	G	G1	G2	$\varnothing H$	L	CH
16	M4	6	M16x1.50	16	18	M5	43	76	97	19	18	5
20	M8	8	M22x1.5	20	20	G1/8	52	91	115	27	25.5	7
25	M10x1.25	10	M22X1.5	22	22	G1/8	52	96	124	30	28.5	9

Traction & Thrust Forces (6 Bar)

\varnothing mm	THRUST FORCE (N)	TRACTION FORCE (N)
16	105	88
20	165	141
25	266	219

Dynamax® ISO 6432 Cylinders

Mounting Accessories for Minicylinders

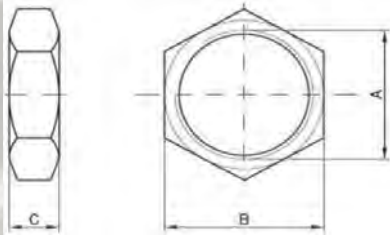

End Mounting Nut

Ø mm	A	B	C	Part Number
8-10	M12x1.25	19	7	ANA-40B
12-16	M16x1.5	22	5	ANT-12/16
20-25	M22x1.5	27	8	ANT-20/25

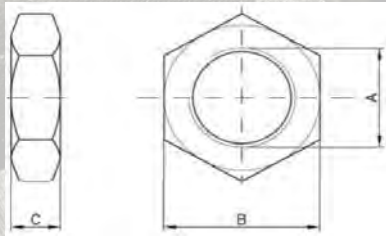

Piston Rod Nut

Ø mm	A	B	C	Part Number
8-10	M4	7	3.2	ANA-8/10
12-16	M6	10	4	ANA-12/16
20	M8x1.25	13	5	ANA-20
25	M10x1.25	17	6	ANA-25

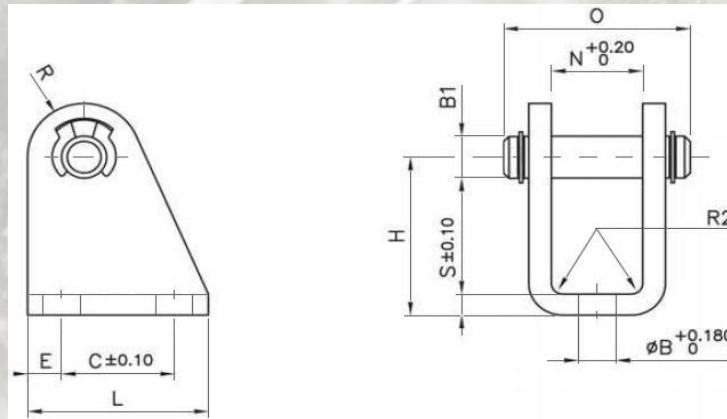

Rear Hinge

Ø mm	L	H	B1	S	E	C	N	B	O	R	R2	Part Number
8-10	20	24	4	2.5	3.75	12.5	8.1	4.5	18	5	1.5	AF-10
12-16	25	27	6	3	5	15	12.1	5.5	24	7	1.5	AF-12-16
20-25	32	30	8	4	6	20	16.1	6.6	31	10	2	AF-20-25

Dynamax® ISO 6432 Cylinders

Mounting Accessories for Minicylinders

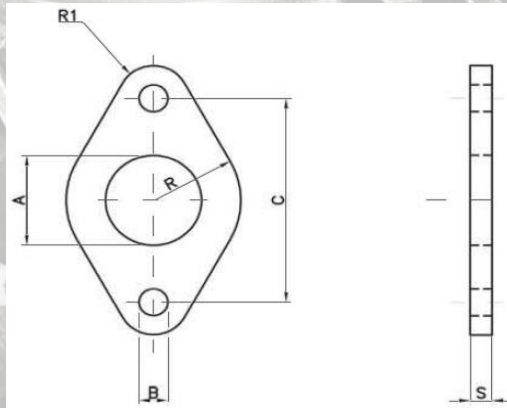

Flange

∅ mm	A	B	C	R	R1	S	Part Number
8-10	12	4.5	30	11	5	3	PL-10
12-16	16	5.5	40	15	6	4	PL-12-16
20-25	22	6.5	50	20	8	5	PL-20-25

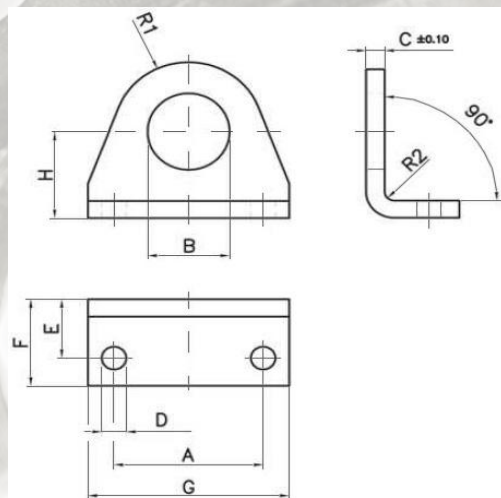

Foot

∅ mm	A	B	C	D	E	F	G	H	R1	R2	Part Number
8-10	25	12	3	4.5	11	16	35	16	10	1.5	EN-10
12-16	32	16.1	4	5.5	14	20	42	20	13	2	EN-12-16
20-25	40	22.1	5	6.6	17	25	54	25	20	2.5	EN-20-25

Dynamax® ISO 6432 Cylinders

Mounting Accessories for Minicylinders

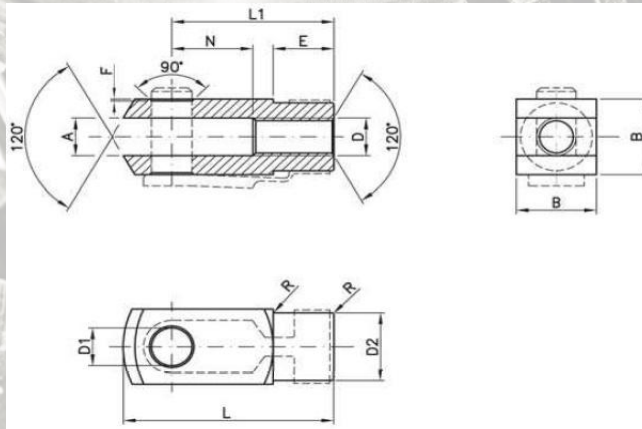

Clevis with Lockable Pin

D	A	F	L1	N	E	B	D1	R	D2	L	Part Number
M4	4	0.5	16	8	6	8	4	0.5	8	21	FE-4
M6	6	0.5	24	12	9	12	6	0.5	10	31	FE-6
M8	8	0.5	32	16	12	16	8	0.5	14	42	FE-8
M10x1.25	10	0.5	40	20	15	20	10	0.5	18	52	FEC10x125

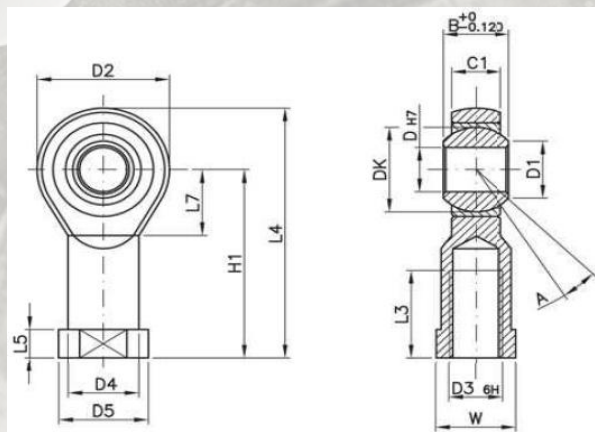

Spherical Rod End

D3	W	L3	A	D	DK	D1	C1	B	D4	D5	L5	L7	H1	L4	D2	Part Number
M4	9	10	13°	5	11.112	7.7	6	8	9	11	4	10	27	36	18	FER-4
M6	11	12	13°	6	12.7	8.9	6.75	9	10	13	5	11	30	40	20	FER-6
M8	14	16	14°	8	15.875	10.4	9	12	12.5	16	5	13	36	48	24	FER-8
M10x1.25	17	20	13°	10	19.050	12.9	10.5	14	15	19	6.5	15	43	57	28	FER10x125

Dynamax® ISO 6432 Cylinders

Position Sensing for Minicylinders

UL-03 Series

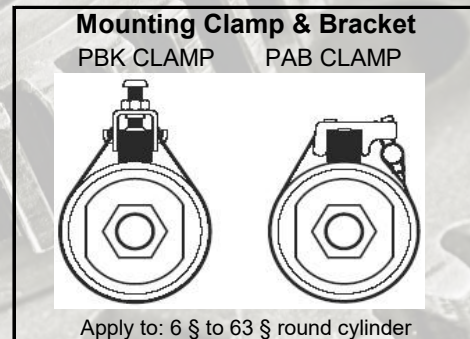

Specifications

CHARACTERISTIC/TYPE	UL-03R	UL-03N	UL-03P
Switching Logic	SPST Normally Open	Solid State Output, Normally Open	
Sensor Type	Reed Switch	NPN Current Sinking	PNP Current Sourcing
Operating Voltage (Note 1)	5 ~ 240V DC/AC	5 ~ 28V DC	
Switching Current	100 mA max.	200 mA max.	
Switching Rating	10 W max.	6 W max.	
Current Consumption		20 mA max. @ 24V (Switch Active)	18 mA max. @ 24V (Switch Active)
Voltage Drop	2.5 V max. @ 40mA DC	0.5 V max. @ 200 mA (Resistive Load)	
Leakage Current		0.01 mA max.	
Indicator	Red LED	Red LED	Green LED
Cable	2.8 §, 2C, OIL RESISTANT PVC	2.8 §, 3C, OIL RESISTANT PVC	
Sensitivity (Note 2)		60 Gauss	
Max. Switching Frequency	200 Hz	1000 Hz	
Temperature Range		-10 ~ 70	
Shock (Note 3)	30 G	50 G	
Vibration (Note 4)		9G	
Enclosure Classification		IP 67 (NEMA 6)	
Protection Circuit		Power Source Reverse Polarity; Surge Suppression	

Wiring Diagram

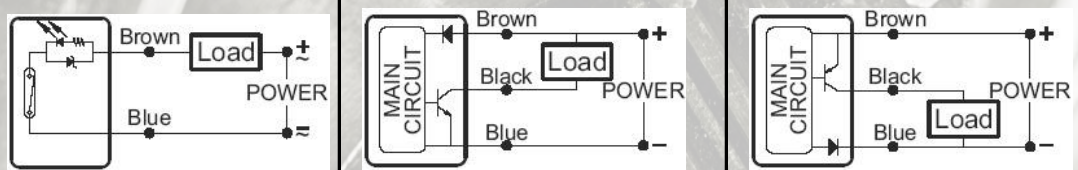

UL-03R-03
UL-03R-QC8

UL-03N(P)
UL-03N(P)-QC8

M8 Quick Connector (IEC61076-2-101)

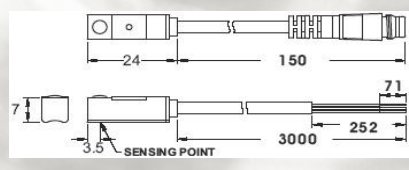
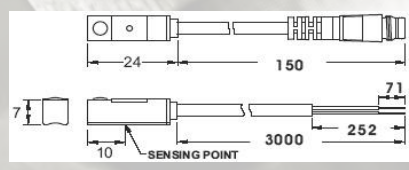

- NOTE: 1. The max. Operating voltage of UL-15R-QD8 is 60V AC/DC (based on IEC61076-2-101).
 2. Measuring standard target: 15.5 * 8 * 5t (Anisotropic Rubber Magnet).
 3. Sin Wave /X - -Y- -Z 3 Directions / 3 Times Each Direction/ 11mS Each Time
 4. Double Amplitude 1.5mm / 10Hz ~55Hz~10Hz (Sweep 1 min) /X - -Y- -Z
 3 Directions / 1 Hour each Time

Dynamax® ISO 6432 Cylinders

Position Sensing for Minicylinders

UL-15 Series

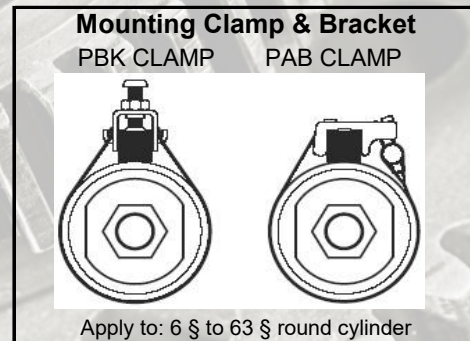

Specifications

CHARACTERISTIC/TYPE	UL-15R	UL-15N	UL-15P
Switching Logic	SPST Normally Open	Solid State Output, Normally Open	
Sensor Type	Reed Switch	NPN Current Sinking	PNP Current Sourcing
Operating Voltage (Note 1)	5 ~ 240V DC/AC	5 ~ 28V DC	
Switching Current	100 mA max.	200 mA max.	
Switching Rating	10 W max.	6 W max.	
Current Consumption		20 mA max. @ 24V (Switch Active)	18 mA max. @ 24V (Switch Active)
Voltage Drop	2.5 V max. @ 40mA DC	0.5 V max. @ 200 mA (Resistive Load)	
Leakage Current		0.01 mA max.	
Indicator	Red LED	Red LED	Green LED
Cable	2.8 §, 2C, OIL RESISTANT PVC	2.8 §, 3C, OIL RESISTANT PVC	
Sensitivity (Note 2)		60 Gauss	
Max. Switching Frequency	200 Hz	1000 Hz	
Temperature Range		-10 ~ 70	
Shock (Note 3)	30 G	50 G	
Vibration (Note 4)		9G	
Enclosure Classification		IP 67 (NEMA 6)	
Protection Circuit		Power Source Reverse Polarity; Surge Suppression	

Wiring Diagram

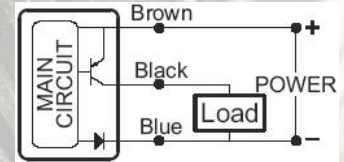
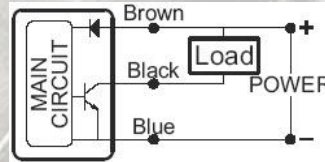
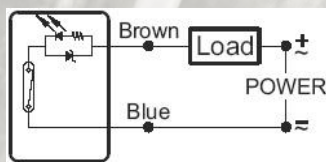

UL-15R-03
UL-15R-QD8

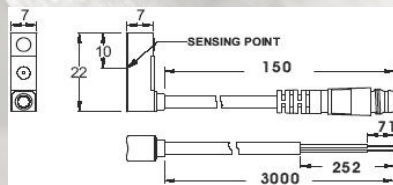

UL-15N(P)-03
UL-15N(P)-QD8

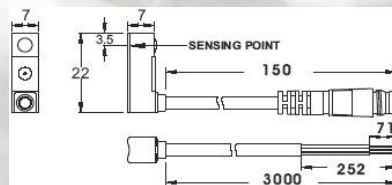

M8 Quick Connector (IEC61076-2-101)



- NOTE: 1. The max. Operating voltage of UL-15R-QD8 is 60V AC/DC (based on IEC61076-2-101).
 2. Measuring standard target: 15.5 * 8 * 5t (Anisotropic Rubber Magnet).
 3. Sin Wave /X - -Y- -Z 3 Directions / 3 Times Each Direction/ 11mS Each Time
 4. Double Amplitude 1.5mm / 10Hz ~55Hz~10Hz (Sweep 1 min) /X - -Y- -Z
 3 Directions / 1 Hour each Time

Dynamax® ISO 6432 Cylinders

Position Sensing for Minicylinders

UL-20 Series

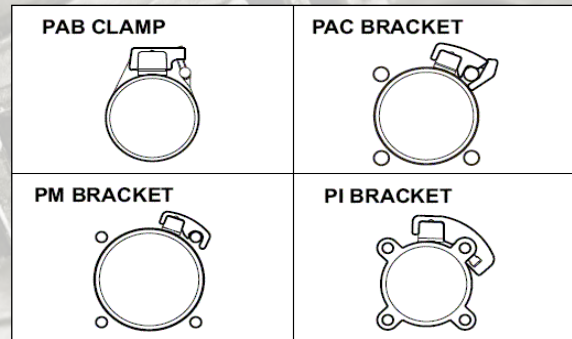
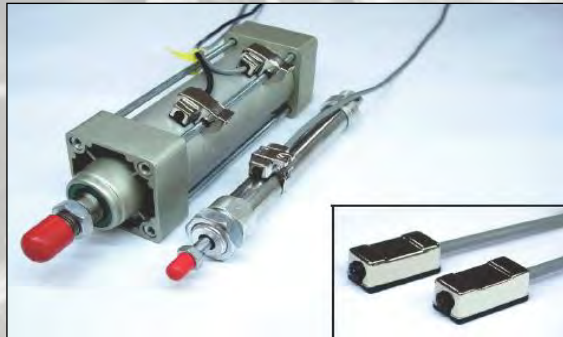

Specifications

CHARACTERISTIC/TYPE	UL-20R	UL-20N	UL-20P
Switching Logic	SPST Normally Open	Solid State Output, Normally Open	
Sensor Type	Reed Switch	NPN Current Sinking	PNP Current Sourcing
Operating Voltage (Note 1)	5 ~ 240V DC/AC	5 ~ 28V DC	
Switching Current	100 mA max.	200 mA max.	
Switching Rating	10 W max.	6 W max.	
Current Consumption		15 mA max. @ 24V (Switch Active)	16 mA max. @ 24V (Switch Active)
Voltage Drop	2.5 V max. @ 40mA DC	1.5 V max. @ 200 mA (Resistive Load)	
Leakage Current		0.01 mA max.	
Indicator	Red LED	Red LED	Green LED
Cable	4.0 §, 2C, OIL RESISTANT PVC	4.0 §, 3C, OIL RESISTANT PVC	
Sensitivity (Note 2)	70 Gauss	60 Gauss	
Max. Switching Frequency	200 Hz	1000 Hz	
Temperature Range		-10 ~ 70	
Shock (Note 3)	30 G	50 G	
Vibration (Note 4)		9G	
Enclosure Classification		IP 67 (NEMA 6)	
Protection Circuit		Power Source Reverse Polarity; Surge Suppression; O/P Short Circuit Protect	

Wiring Diagram

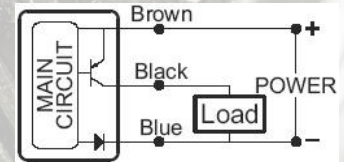
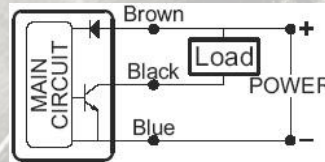
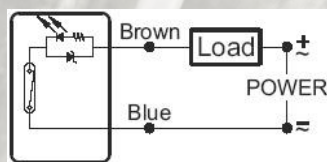

UL-20R-03
UL-20R-QC8

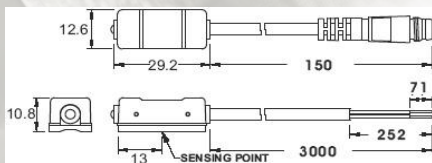

UL-20N(P)-03
UL-20N(P)-QC8

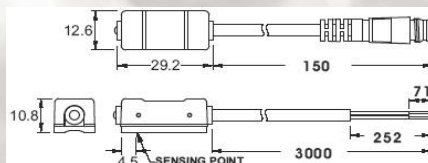

M8 Quick Connector (IEC61076-2-101)



- NOTE: 1. The max. Operating voltage of UL-20R-QC8 is 60V AC/DC (based on IEC61076-2-101).
 2. Measuring standard target: 15.5 * 8 * 5t (Anisotropic Rubber Magnet).
 3. Sin Wave /X - -Y- -Z 3 Directions / 3 Times Each Direction/ 11mS Each Time
 4. Double Amplitude 1.5mm / 10Hz ~55Hz~10Hz (Sweep 1 min) /X - -Y- -Z
 3 Directions / 1 Hour each Time

Dynamax® ISO 6432 Cylinders

Position Sensing for Minicylinders

UL-21 Series

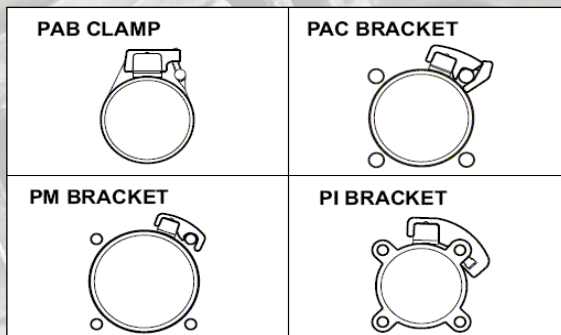

Specifications

CHARACTERISTIC/TYPE	UL-21R	UL-21N	UL-21P
Switching Logic	SPST Normally Open	Solid State Output, Normally Open	
Sensor Type	Reed Switch	NPN Current Sinking	PNP Current Sourcing
Operating Voltage (Note 1)	5 ~ 240V DC/AC	5 ~ 28V DC	
Switching Current	100 mA max.	200 mA max.	
Switching Rating	10 W max.	6 W max.	
Current Consumption		15 mA max. @ 24V (Switch Active)	16 mA max. @ 24V (Switch Active)
Voltage Drop	2.5 V max. @ 40mA DC	1.5 V max. @ 200 mA (Resistive Load)	
Leakage Current		0.01 mA max.	
Indicator	Red LED	Red LED	Green LED
Cable	4.0 §, 2C, OIL RESISTANT PVC	4.0 §, 3C, OIL RESISTANT PVC	
Sensitivity (Note 2)	70 Gauss	60 Gauss	
Max. Switching Frequency	200 Hz	1000 Hz	
Temperature Range		-10 ~ 70	
Shock (Note 3)	30 G	50 G	
Vibration (Note 4)		9G	
Enclosure Classification		IP 67 (NEMA 6)	
Protection Circuit		Power Source Reverse Polarity; Surge Suppression; O/P Short Circuit Protect	

Wiring Diagram

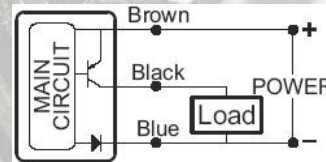
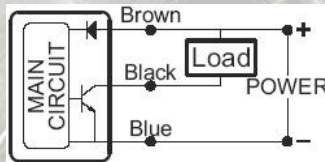
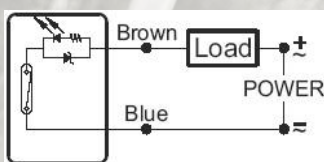

UL-21R-03
UL-21R-QC8

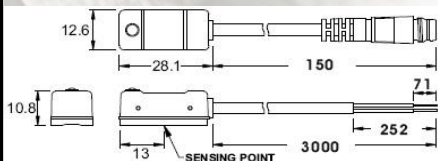

UL-21N(P)-03
UL-21N(P)-QC8

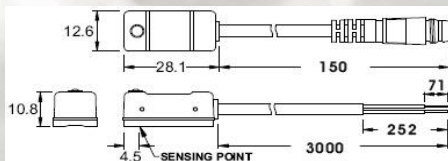

M8 Quick Connector (IEC61076-2-101)

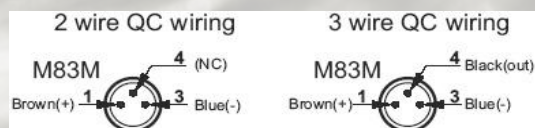

- NOTE: 1. The max. Operating voltage of UL-21R-QC8 is 60V AC/DC (based on IEC61076-2-101).
 2. Measuring standard target: 15.5 * 8 * 5t (Anisotropic Rubber Magnet).
 3. Sin Wave /X - -Y- -Z 3 Directions / 3 Times Each Direction/ 11mS Each Time
 4. Double Amplitude 1.5mm / 10Hz ~55Hz~10Hz (Sweep 1 min) /X - -Y- -Z
 3 Directions / 1 Hour each Time

Dynamax® ISO 6432 Cylinders

Position Sensing for Minicylinders

UL-30 Series

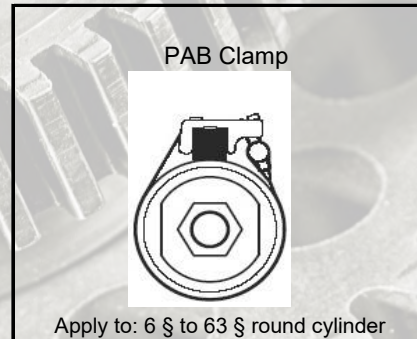

Specifications

CHARACTERISTIC/TYPE	UL-30R	UL-30N	UL-30P
Switching Logic	SPST Normally Open	Solid State Output, Normally Open	
Sensor Type	Reed Switch	NPN Current Sinking	PNP Current Sourcing
Operating Voltage (Note 1)	5 ~ 240V DC/AC	5 ~ 28V DC	
Switching Current	100 mA max.	200 mA max.	
Switching Rating	10 W max.	6 W max.	
Current Consumption		19 mA max. @ 24V (Switch Active)	16 mA max. @ 24V (Switch Active)
Voltage Drop	2.5 V max. @ 40mA DC	1.5 V max. @ 200 mA (Resistive Load)	
Leakage Current		0.01 mA max.	
Indicator	Red LED	Red LED	Green LED
Cable	2.8 §, 2C, OIL RESISTANT PVC	2.8 §, 3C, OIL RESISTANT PVC	
Sensitivity (Note 2)	45 Gauss	40 Gauss	
Max. Switching Frequency	200 Hz	1000 Hz	
Temperature Range		-10 ~ 70	
Shock (Note 3)	30 G	50 G	
Vibration (Note 4)		9G	
Enclosure Classification	IP 67 (NEMA 6)		
Protection Circuit		Power Source Reverse Polarity; Surge Suppression; O/P Short Circuit Protect	

Wiring Diagram

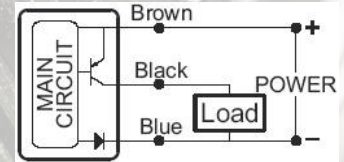
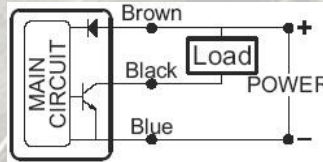
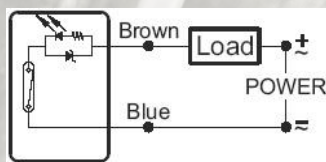

UL-30R-03
UL-30R-QC8

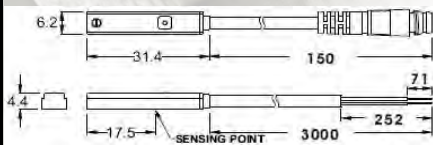

UL-30N(P)-03
UL-30N(P)-QC8

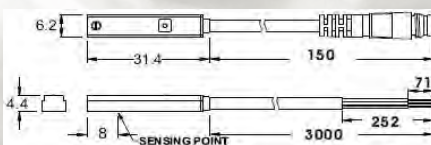

M8 Quick Connector (IEC61076-2-101)

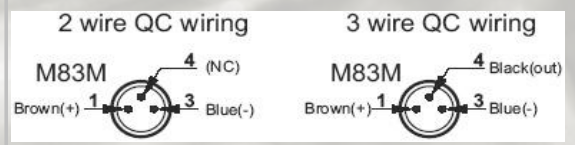

- NOTE: 1. The max. Operating voltage of UL-30R-QC8 is 60V AC/DC (based on IEC61076-2-101).
 2. Measuring standard target: 15.5 * 8 * 5t (Anisotropic Rubber Magnet).
 3. Sin Wave /X - -Y- -Z 3 Directions / 3 Times Each Direction/ 11mS Each Time
 4. Double Amplitude 1.5mm / 10Hz ~55Hz~10Hz (Sweep 1 min) /X - -Y- -Z
 3 Directions / 1 Hour each Time

Dynamax® ISO 6432 Cylinders

Position Sensing for Minicylinders

UL-33 Series

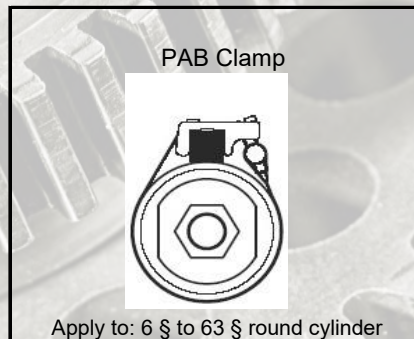

Specifications

CHARACTERISTIC/TYPE	UL-33R	UL-33N	UL-33P
Switching Logic	SPST Normally Open	Solid State Output, Normally Open	
Sensor Type	Reed Switch	NPN Current Sinking	PNP Current Sourcing
Operating Voltage (Note 1)	5 ~ 240V DC/AC	5 ~ 28V DC	
Switching Current	100 mA max.	200 mA max.	
Switching Rating	10 W max.	6 W max.	
Current Consumption		19 mA max. @ 24V (Switch Active)	16 mA max. @ 24V (Switch Active)
Voltage Drop	2.5 V max. @ 40mA DC	1.5 V max. @ 200 mA (Resistive Load)	
Leakage Current		0.01 mA max.	
Indicator	Red LED	Red LED	Green LED
Cable	2.8 §, 2C, OIL RESISTANT PVC	2.8 §, 3C, OIL RESISTANT PVC	
Sensitivity (Note 2)	45 Gauss	40 Gauss	
Max. Switching Frequency	200 Hz	1000 Hz	
Temperature Range		-10 ~ 70	
Shock (Note 3)	30 G	50 G	
Vibration (Note 4)		9G	
Enclosure Classification	IP 67 (NEMA 6)		
Protection Circuit		Power Source Reverse Polarity; Surge Suppression; O/P Short Circuit Protect	

Wiring Diagram

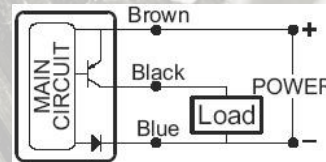
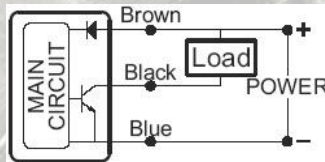
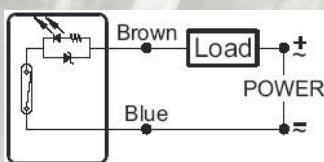

UL-33R-03
UL-33R-QC8

UL-33N(P)-03
UL-33N(P)-QC8

M8 Quick Connector (IEC61076-2-101)

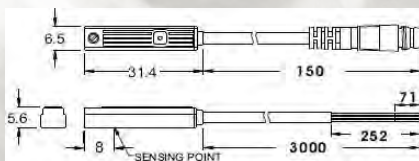
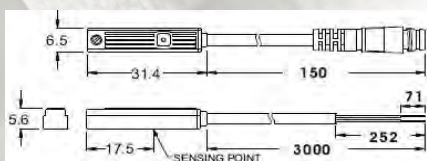

- NOTE: 1. The max. Operating voltage of UL-33R-QC8 is 60V AC/DC (based on IEC61076-2-101).
 2. Measuring standard target: 15.5 * 8 * 5t (Anisotropic Rubber Magnet).
 3. Sin Wave /X - -Y- -Z 3 Directions / 3 Times Each Direction/ 11mS Each Time
 4. Double Amplitude 1.5mm / 10Hz ~55Hz~10Hz (Sweep 1 min) /X - -Y- -Z
 3 Directions / 1 Hour each Time

Dynamax® ISO 6432 Cylinders

Position Sensing Brackets for Minicylinders

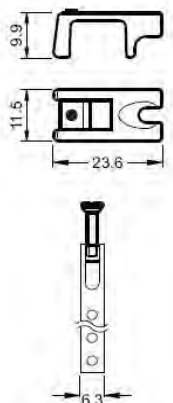
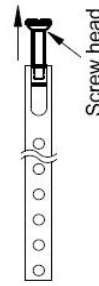
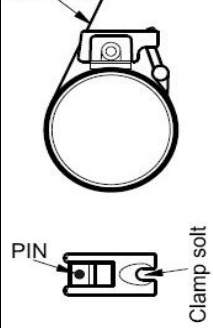
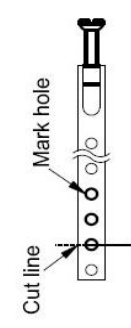
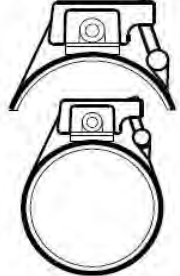
	PAB	Step 1	Step 2	Step 3	Step 4
	<p>PAB -01 For 12ø ~ 63ø round cylinder</p> <p>PAB -02 For 12ø ~ 125ø round cylinder</p>	<p>Start by turning screw 3 - 4 turns onto barrel nut at the end of the band assembly.</p>	<p>1. Place the screw head into the clamp and wrap the band around the cylinder.</p> <p>2. Position the pin with the nearest hole on the band and mark the hole with a permanent marker.</p>	<p>1. Remove clamp assembly.</p> <p>2. Cut the band at the next adjacent hole from the marked hole.</p>	<p>the flat slot, opposite the clamp slot.</p> <p>2. Place the chosen hole over the pin and bend the band firmly down with thumb pressure.</p> <p>3. Wrap the band around the cylinder barrel and re-insert screw head into clamp.</p> <p>4. Position the switch and tighten.</p>
	 <p>Screw head</p>	 <p>Mark hole</p> <p>PIN</p> <p>Clamp slot</p>	 <p>Mark hole</p> <p>Cut line</p>	<p>ATTENTION!</p> <p>Do not over tighten! Damage to the switch and or cylinder may occur.</p> 	

PAB CLAMP	PBS	Mounts UL-33 series on Round Cylinder
PBT CLAMP	PBT	Mounts UL-30 & UL-31 series on Round Cylinder

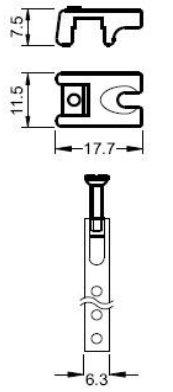
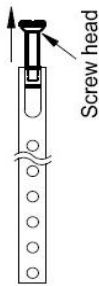
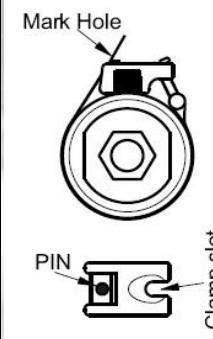
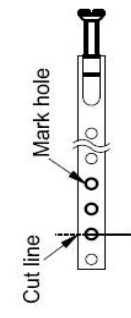
	<p>PBS-01 PBT-01 For 12ø ~ 63ø round cylinder</p> <p>PBS-02 PBT-02 For 12ø ~ 125ø round cylinder</p>	Step 1	Step 2	Step 3	Step 4
	<p>Start by turning screw 3 - 4 turns onto barrel nut at the end of the band assembly.</p>	<p>1. Place the screw head into the clamp and wrap the band around the cylinder.</p> <p>2. Position the pin with the nearest hole on the band and mark the hole with a permanent marker.</p>	<p>1. Remove clamp assembly.</p> <p>2. Cut the band at the next adjacent hole from the marked hole.</p>	<p>the flat slot, opposite the clamp slot.</p> <p>2. Place the chosen hole over the pin and bend the band firmly down with thumb pressure.</p> <p>3. Wrap the band around the cylinder barrel and re-insert screw head into clamp.</p> <p>4. Position the switch and tighten.</p>	
	 <p>Screw head</p>	 <p>Mark Hole</p> <p>PIN</p> <p>Clamp slot</p>	 <p>Mark hole</p> <p>Cut line</p>	<p>ATTENTION!</p> <p>Do not over tighten! Damage to the switch and or cylinder may occur.</p> 